

# Merlin®

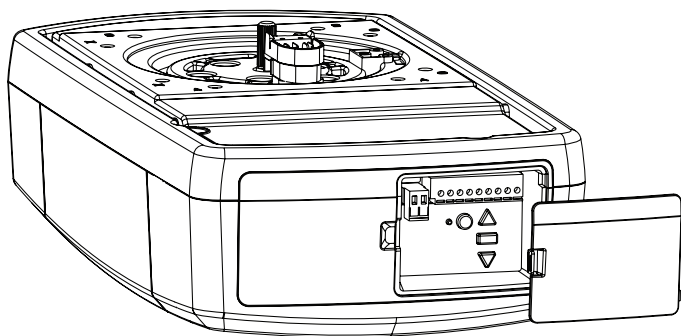

[gomerlin.com.au](http://gomerlin.com.au)

[gomerlin.co.nz](http://gomerlin.co.nz)



battery backup  
compatible



capable

# Commander Elite MS105MYQ

## Sectional and Tilt Garage Door Opener Installation and Operating Instructions



Australia

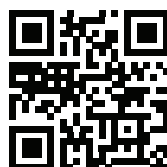

New Zealand

Owners Copy: SAVE THESE INSTRUCTIONS for future reference



This manual contains **IMPORTANT SAFETY** information  
DO NOT PROCEED WITH THE INSTALLATION BEFORE READING THOROUGHLY



## Limited Warranty in Australia and New Zealand

### Merlin® Commander Elite MS105MYQ

#### Garage Sectional and Tilt Door Opener

#### 1 Your consumer rights and guarantees

This Limited Warranty is provided by Chamberlain Australia Pty Ltd, Chamberlain New Zealand Limited (**Chamberlain**), contact details in Section 5 below. This Limited Warranty applies to the Merlin® Commander Elite MS105MYQ unit (Unit) purchased in Australia and New Zealand, and gives you benefits which are in addition to your consumer rights and remedies under the Australian Consumer Law (or corresponding New Zealand consumer protection laws).

You can find out more information about your consumer rights and guarantees which the law provides in Australia at [www.accc.gov.au](http://www.accc.gov.au), in New Zealand at [www.consumerprotection.govt.nz](http://www.consumerprotection.govt.nz). We also provide this statement as required under the Australian Consumer Law:

Our goods come with guarantees that cannot be excluded under the Australian Consumer Law. You are entitled to a replacement or refund for a major failure and for compensation for any other reasonably foreseeable loss or damage. You are also entitled to have the goods repaired or replaced if the goods fail to be of acceptable quality and the failure does not amount to a major failure.

#### 2 What does our Limited Warranty cover?

Chamberlain warrants that, when purchased new in Australia or New Zealand, the Unit (all parts of the Unit other than globes and batteries) is free from defects in materials and workmanship (Limited Warranty) for the Limited Warranty period, subject to the terms and conditions of this Limited Warranty.

The Limited Warranty period (for Accessories see below) is 7 years (84 months) or 15,000 cycles (each opening and closing of the garage door equals 1 cycle) whichever comes first, from the date of purchase of the Unit when installed by a Professional Dealer authorised by Chamberlain in residential premises with a residential specified garage door that is designed for the sole purpose of a single-family dwelling.

The Limited Warranty period for remote controlled transmitters and accessories included with the Unit (Accessories) is 12 months from the date of purchase.

#### 3 Limited Warranty Conditions

The following terms and conditions apply to your Limited Warranty:

- our Limited Warranty is effective from date of purchase as indicated in Section 2 above;
- proof of purchase of the Unit is required;
- purchaser must ensure the garage door is serviced by a Chamberlain authorised dealer or qualified technician during the period 24 to 36 months and 60 to 72 months after the date of purchase. If your door binds, sticks, or is out of balance, then it must not be used until serviced by a Chamberlain authorised dealer or qualified technician. The garage door service fee will be at the purchaser's expense.

Please also see the User Manual for the Unit available on our website.

#### 4 What is not covered

- Batteries and globes are not covered under the Chamberlain Limited Warranty.
- Travel costs incurred by Chamberlain or its authorised dealer in either travelling to and from areas outside a capital city area. These costs will be at the purchaser's expense.
- Additional access costs incurred by Chamberlain or its authorised dealer in obtaining access to premises where the Unit is not readily accessible. These costs will be at the purchaser's expense.

Our Limited Warranty covers defects as explained, and does not cover all problems and mishaps that may occur in relation to the Unit including:

- when the unit is not installed within outlined specification for that unit or as outlined within the user manual;
- you got what you asked for but simply changed your mind, found it cheaper somewhere else, decided you did not like the purchase or had no use for it;
- you misused the Unit in any way that caused the problem;
- you knew of or were made aware of any deficiencies with the Unit before date of purchase;
- use of the Unit with controls or third party devices or software which has not been supplied, or pre-approved, by Chamberlain;
- problems relating to or residing in third party hardware, software or other items with which our product is used;

- any loss of data related to you or provided by you, or loss related to downtime associated with use of the product, whether through power outage, failure of internet or wireless connectivity, network disruptions, or otherwise;
- non-compliance with the relevant instructions in the User Manual;
- tampering, neglect, abuse, wear and tear, accident, electrical storm, excessive use or conditions other than normal use;
- problems with, or relating to, the garage door or garage door hardware, including but not limited to the door springs, door rollers, door alignment, hinges, guides, slats and drums;
- problems caused by electrical faults or replacement of batteries or light bulbs, blown fuses, electrical surges, power surges or power strikes, fire, flood, rain, water, lightning or storms;
- water or moisture ingress that causes corrosion or electrical malfunction;
- corrosion caused by sea air if located near a waterway, beach etc;
- fitment to a commercial door or in a commercial operating application, installation of a residential garage door opener in a commercial or industrial premises other than a single-family dwelling;
- lack of proper maintenance, service or care of the door and/or Unit; and/or
- damage caused by insects, pests or other after sale damage caused by events or accidents outside Chamberlain's reasonable control and not arising under normal and standard operating conditions.

#### 5 Where you need help with our product

If you have a problem with the Unit or if you are concerned it may be defective, please contact our Customer Service team below:

**Australia** Phone toll free 1800 638 234  
Fax toll free 1800 888 121  
Address Unit 1, 75 Epping Road North Ryde, NSW 2113  
Email [customerservice@chamberlainnz.com](mailto:customerservice@chamberlainnz.com)  
Website [www.gomerlin.com.au](http://www.gomerlin.com.au)

**New Zealand** Phone toll free 0800 653 667  
Auckland Phone 09 477 2823  
Fax toll free 0800 653 663  
Email [customerservice@chamberlainnz.com](mailto:customerservice@chamberlainnz.com)  
Website [www.gomerlin.co.nz](http://www.gomerlin.co.nz)

As a first step, our Customer Service team will provide product support assistance to help you try to resolve the problem and in some cases, replacement parts for "do it yourself repairs". If our technical team need to see the product to determine the nature of the fault, we will arrange an inspection by an experienced technician, or ask that you send the product to us.

If your product was installed at your premises by an authorised installer, please contact the installer indicated in your sales documents for prompt on-site service, or consult our Customer Service team if you need help in finding a local service technician. A service fee for on-site service may apply.

Authorisation from Chamberlain is required for warranty service under this Limited Warranty.

#### 6 Delivery Charges

If an inspection is required in order to determine the nature of the fault, please send the Unit freight paid and well packaged in accordance with our instructions. Any costs associated with transporting the Unit will be at Chamberlain's cost if the Unit has breached a statutory consumer guarantee. Repairs and replacement parts provided under this Limited Warranty are free of charge (and repaired items or replacement parts for Units found to be defective will be returned to you at our cost), and warranted by Chamberlain for the remaining portion of the original warranty period. However, if you make a claim under this Limited Warranty, and this Limited Warranty does not apply, or if the law does not provide you with a statutory right or remedy as a consumer, you may be required to pay labour, assessment and/or freight costs and delivery charges to repair, replace and/or return the Unit to you.

#### 7 How to register your product

Please register your Unit and contact details at this link [www.gomerlin.com.au/warranty-registration/](http://www.gomerlin.com.au/warranty-registration/) for Australia, or [www.gomerlin.co.nz/register-your-warranty/](http://www.gomerlin.co.nz/register-your-warranty/) for New Zealand, so that we or your authorised installer can locate your details and provide you with product support assistance as quickly as possible, and keep you up to date with product updates. Registration can also be done by contacting Chamberlain Customer Service.

#### 8 Important Reminder

All other guarantees (other than your statutory rights and guarantees as a consumer under applicable laws) are excluded to the fullest extent that we may lawfully do so. Unless the law requires us to do so, we do not accept any other liability, such as compensation for damages, injury or loss.

Last updated: [25th October 2022]

## 35 TROUBLE SHOOTING

### 1. Opener doesn't operate from either door control or transmitter:

- Does the opener have electric power? Plug lamp into outlet. If it doesn't light, check the fuse box or the circuit breaker. (Some outlets are controlled by a wall switch.)
- Have you disengaged all door locks? Review installation instruction warnings on page 2.
- Is there a build-up of ice or snow under door? The door may be frozen to ground. Remove any obstruction.
- The garage door spring may be broken. Have it replaced.

### 2. Door operates from door control but not from transmitter:

- Replace batteries in the transmitter if necessary.
- If you have two or more transmitters and only one operates, review Program Your Opener, Transmitter and Keyless Entry.

### 3. Transmitter has short range:

- Check the battery in the transmitter is fully charged.
- Change the location of the transmitter in the car.
- A metal garage door, foil-backed insulation or metal siding will reduce the transmission range.

### 4. Door reverses for no apparent reason and opener light flashes 10 times:

Check The Protector System™ (IR Beams) (if you have installed this accessory). If the light is flashing, correct alignment.

If the Protector System™ (IR Beams) is installed and needs to be removed, the Opener will need to be reprogrammed as follows:

- Remove the IR Beam wiring from the Opener.
- Turn the power OFF for 5 seconds.
- Turn the power ON for 5 seconds.
- Again turn the power OFF for 5 seconds.
- Turn the power back on and test the opener for normal operation.

### 5. The garage door opens and closes by itself:

Make sure transmitter button is not stuck "on".

### 6. Door stops but doesn't close completely:

Repeat Programming the Travel Limits.

Repeat safety reverse test after any adjustment of door arm length, close force or down limit adjustments.

### 7. Door opens but won't close:

- Check The Protector System™ (IR Beams) (if you have installed this accessory). If the light on The Protector System™ (IR Beams) are flashing, correct the alignment.
- If opener light does not flash and it is a new installation, repeat Programming the Travel Limits.

Repeat the safety reverse test after the adjustment is complete.

### 8. Opener strains:

Door may be unbalanced or springs are broken. Close door and use manual release rope and handle to disconnect trolley. Open and close door manually. A properly balanced door will stay in any point of travel while being supported entirely by its springs. If it does not, call for professional garage door service to correct the problem.

### 9. Opener hums briefly, then won't work:

- Garage door springs are broken. SEE ABOVE.
- If problem occurs on first operation of opener, door is locked. Disable door lock.

Repeat safety reverse test after adjustment is complete.

### 10. Opener won't activate due to power failure:

- Pull manual release rope and handle down once to disconnect trolley. Door can be opened and closed manually. When the power is restored, press the "GREEN" button in the centre of the trolley assembly. The next time the opener is activated, the trolley will re-connect.
- The Outside Quick Release accessory (if fitted) disconnects the trolley from outside the garage in case of power failure.

### 11. The opener runs, but the carriage does not move:

- Check the carriage is not disengaged from the opener. Operate the manual release to re-engage the opener.
- In a new installation, the preassembled Motor Shaft Adapter may have fallen out of the belt sprocket assembly. This adapter is installed during the manufacturing process and may have dislodged.
- In older installations, especially on excessively heavy doors, check the Motor Shaft Adapter has not stripped.

### 12. The Up and DOWN arrows on the control panel are flashing in sequence:

Check the diagnostic code on next page.

# DIAGNOSTICS

## 36 DIAGNOSTIC CHART

Your garage door opener is programmed with self-diagnostic capabilities. The UP and DOWN arrows on the garage opener flash the diagnostic codes.

DIAGNOSTIC CODE		SYMPTOM	POSSIBLE RESOLUTION
UP Arrow Flash(es)	DOWN Arrow Flash(es)		
1	1	The garage door opener will not close and the courtesy light flashes.	The Protector System™ (IR Beams) are not installed, connected or wires may be cut. Inspect The Protector System™ (IR Beams) wires for a disconnected or cut wire.
1	2	The garage door opener will not close and the courtesy light flashes.	There is a short or reversed wire for the The Protector System™ (IR Beams). Inspect safety sensor wire at all staple points and connection points and replace wire or correct as needed.
1	3	The door control will not function.	The wires for the door control are shorted or the door control is faulty. Inspect The the wire at all staple points and connection points and replace wire or correct as needed.
1	4	The garage door opener will not close and the courtesy light flashes.	The Protector System™ (IR Beams) are misaligned or were momentarily obstructed. Realign both sensors to ensure both LEDs are steady and not flickering. Make sure nothing is hanging or mounted on the door that would interrupt the sensors path while closing.
1	5	There is no door movement or motor accelerates before stopping suddenly..	No RPM pulses have been detected. Check the door manually for balance, binding or obstructions. Internally the possible cause may be the motor, logic board or RPM sensor. Try resetting door travel limits. Contact service centre.
1	6	Door continues to move after the motor stops.	RPM pulses have been detected after motor has turned off. Possible broken spring. Check the door is correctly balanced and not creeping up or down. Contact a door service centre.
2	1-5	Opener fails to operate.	Possible logic board failure. Reboot opener by turning the mains power OFF and then ON after 15 seconds. Reprogram the door travel limits and force settings. Contact service centre.
2	6	Unable to set travel limit down direction. Passpoint has not been recognised during programming.	Check the passpoint module has been activated by the chain Position Tab, during the door travel. Reset the travel limits.
3	2	Unable to set the travel or retain position	Check travel module for proper assembly, replace if necessary.
3	3	The battery status LED* is constantly flashing green.	Battery backup charging circuit error, replace logic board *(if applicable).
4	1-4	Door is moving stops and or reverses.	Manually open and close the door. Check for binding or obstructions, such as a broken spring or door lock. If the door is binding or sticking contact a trained door systems technician. If door is not binding or sticking attempt to reprogram travel (refer to "Program the Travel Limits and Force" section).
4	5	Opener runs approximately 150 mm to 200 mm, stops and reverses.	Communication error to travel module. Check travel module connections, replace module if necessary.
5	1-4	Door fails to operate or operates erratically. External accessory wiring failure.	Check the external wiring to the control panel terminal is wired correctly. Turn off power, remove all external wiring, and retest door operation.
5	5	Door opener fails to operate.	Low internal voltage on the logic board, possible power transformer or logic board failure. Service required, call a trained service specialist.